



APPLICATION NOTES

DALI PHANTOM M-80 A

Angled in-ceiling Hi-Fi loudspeaker
with adjustable directivity



IN ADMIRATION OF MUSIC



Content

- Quick specifications 3
- Introduction 4
- You will need 5
- Cut out template 6
- Cables.....7
- Mounting the speaker 8
- Compass Positioning System..... 9
- Applications 10
 - Immersive Audio - Height Channels12
 - In-ceiling Surround Sound13
 - In-ceiling Stereo14
 - Sounds From Room Boundaries15
 - Pivoting tweeter housing.....16
 - Switch adjustable tone controls17

Quick specifications

DALI PHANTOM	M-80 A
Cut-out dimensions	Ø 261 mm Ø 10.28 inches
Mounting depth	134 mm 5.28 inches
Recommended rear volume (backbox)	15 - 100 litres (Optimum 25 litres)
Outer dimensions incl. grille (H x W x D)	Ø 289 x 138.5 mm Ø 11.38 x 5.46 inches

See the User Manual for a list of complete specifications and the Outer Dimensions drawing for complete dimensions – both documents are available on the PHANTOM M-80 A product pages on the DALI website.

www.dali-speakers.com/en/



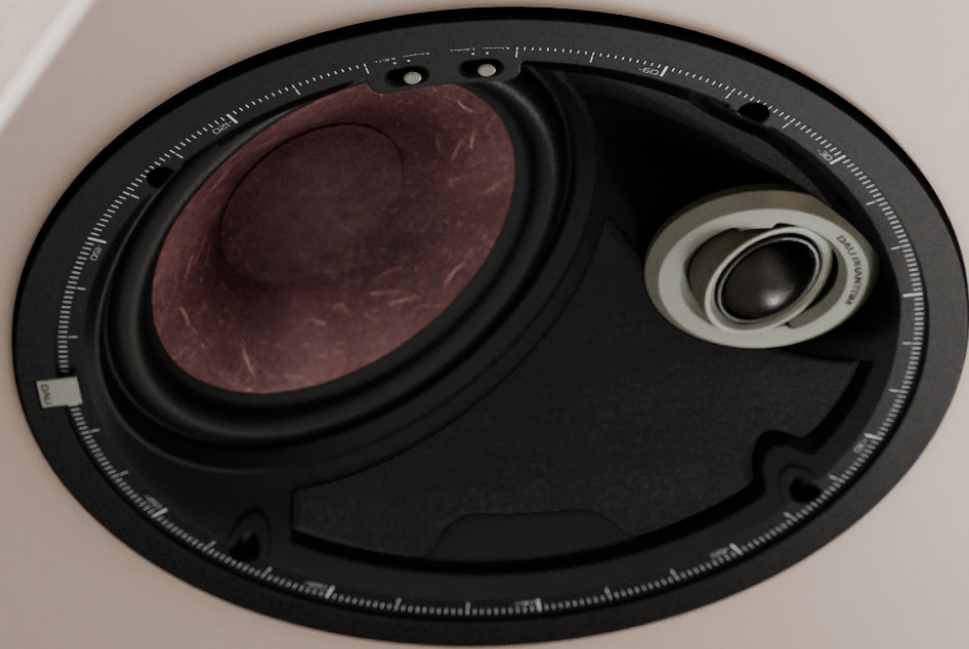

Introduction

These application notes describe some of the most common installation scenarios for the PHANTOM M-80 A custom installation in-ceiling loudspeaker.

The PHANTOM M-80 A combines the best of DALI electro-acoustic design with angled directional dispersion to provide genuine high-end Hi-Fi performance where in-ceiling speakers are the preferred option.

With a DALI designed and SMC equipped 7 inch bass/mid driver, and a DALI designed 28 mm soft dome tweeter, the M-80 A is effectively a high-end DALI speaker for the ceiling.

The M-80 A is a perfect solution for high-end home theatre and music systems that demand discreet installation, adjustable directivity as well as extraordinary sound quality.

INSTALLATION

You will need



Tape measure

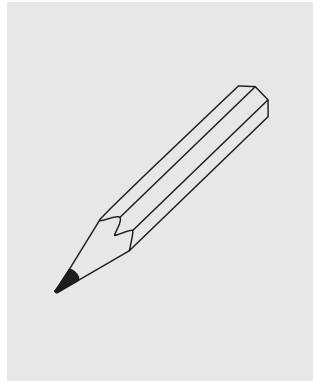

Pencil

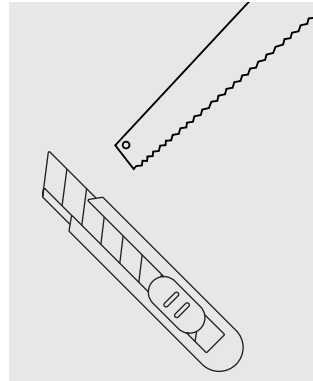

Saw and
box cutter knife

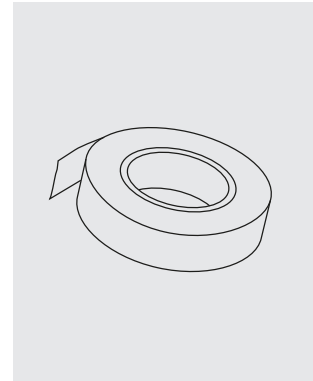

Tape

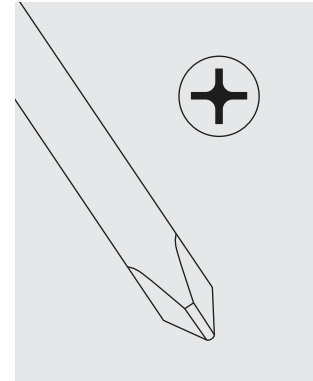

Phillips PH2 driver
or bit

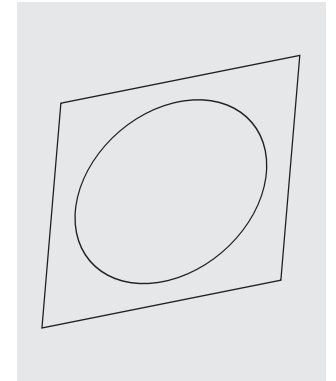

Cut out template

INSTALLATION

Cut out template

- 1** Gently press out the circular part of the cut out template.

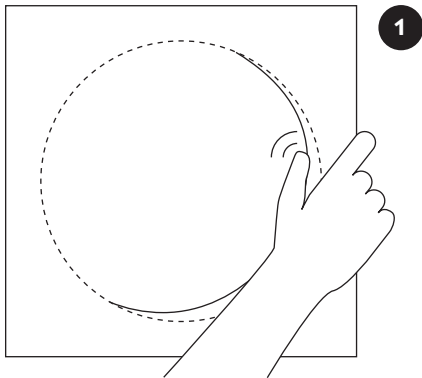

- 2** Tape the template to the mounting position.

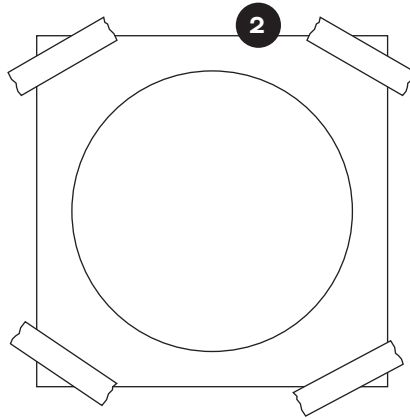

- 3** Draw on the ceiling around the edge of the template.

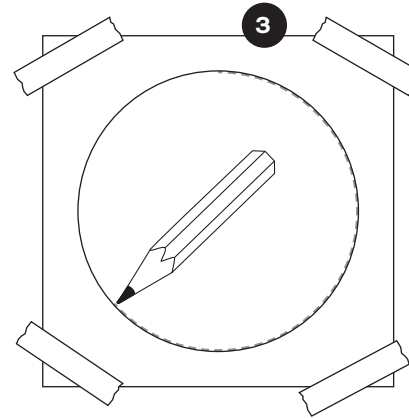

- 4** Cut out a hole in the ceiling.

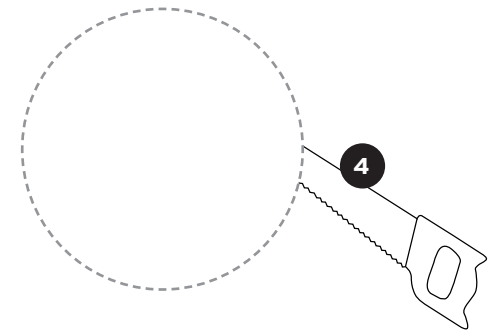

INSTALLATION

Cables

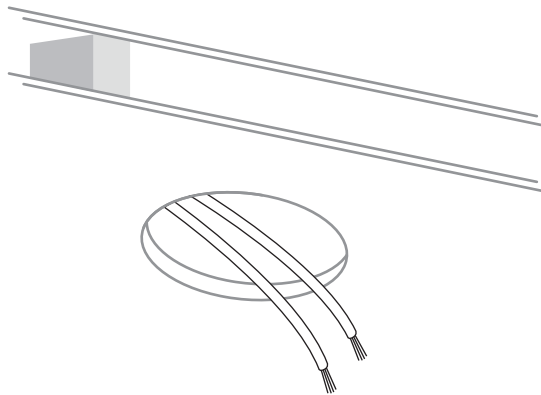

Connect cable to the terminals – being careful to connect the amplifier's (+) terminal to the loudspeaker's red (+) terminal and the amplifier's (-) terminal to the loudspeaker's black (-) terminal.

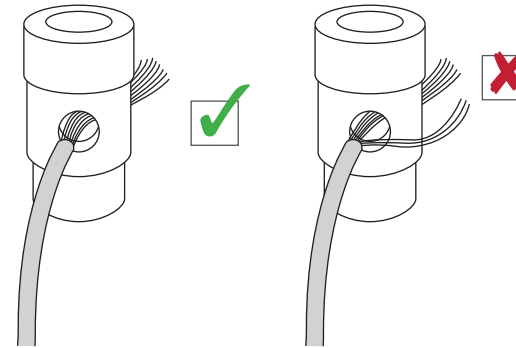

1. Strip 1/2" / 12 mm of cable insulation and gently twist the stranded wires.
2. Insert the cable end into the spring loaded terminals of the speaker.
3. All wire strands must be inside the terminal to avoid any short circuit.

INSTALLATION

Mounting the speaker

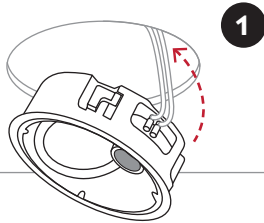

When the cables are connected, insert the loudspeaker in the ceiling.

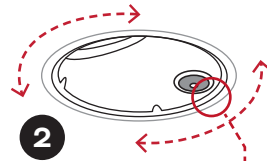

Rotate the speaker using the Compass positioning guide, such that the primary axis (0 degrees) is aligned towards the listening position.

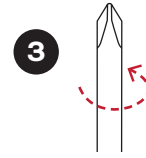
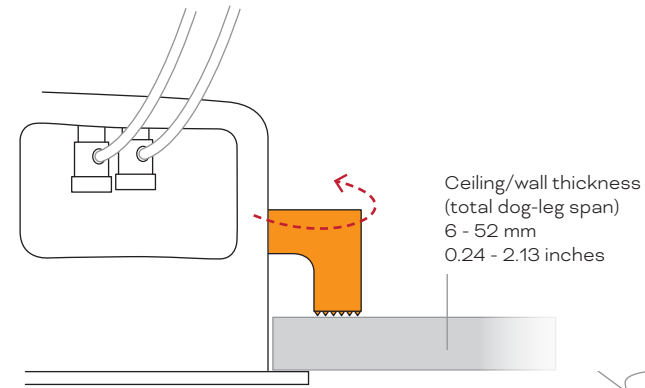

When the correct alignment has been found, tighten all four dogleg screws evenly.

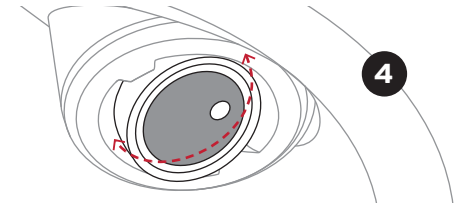

Adjust the tweeter angle, to point towards the main listening position/area.

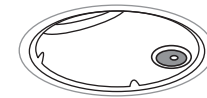

3 x 4



Attach the magnetic grille.



Compass Positioning System

The Compass positioning system markings on the baffle let you align your speakers with ultimate accuracy.

When aligning the direction of the M-80 A the Compass markings on the front baffle can be useful both for fine adjustments and for making sure all loudspeakers are angled similarly towards the listening position.

For optimum dispersion, the M-80 A should be rotated so that the tweeter and the 0 degree Compass mark point towards the desired listening position.



Applications

The PHANTOM M-80 A combines very high-performance audio with brilliant installation versatility.

The following paragraphs describe some potential installation scenarios for the M-80 A custom installation in-ceiling loudspeaker.





Immersive Audio - Height Channels

Immersive audio formats such as Dolby Atmos, DTS-X and AURO-3D require height channel speakers to locate sounds in the three-dimensional spatial audio space.

The PHANTOM M-80 A provides a perfect option for immersive height channels as it enables very high-performance wide bandwidth sound to be installed in the correct placement above the listening position. Furthermore, the angled driver architecture of the M-80 A, and the directional radiation that results, enables sound to be directed towards the listening position, further improving the immersive audio effect. The M-80 A is the perfect choice for any immersive Top Height, Front Height or Rear Height channel applications.

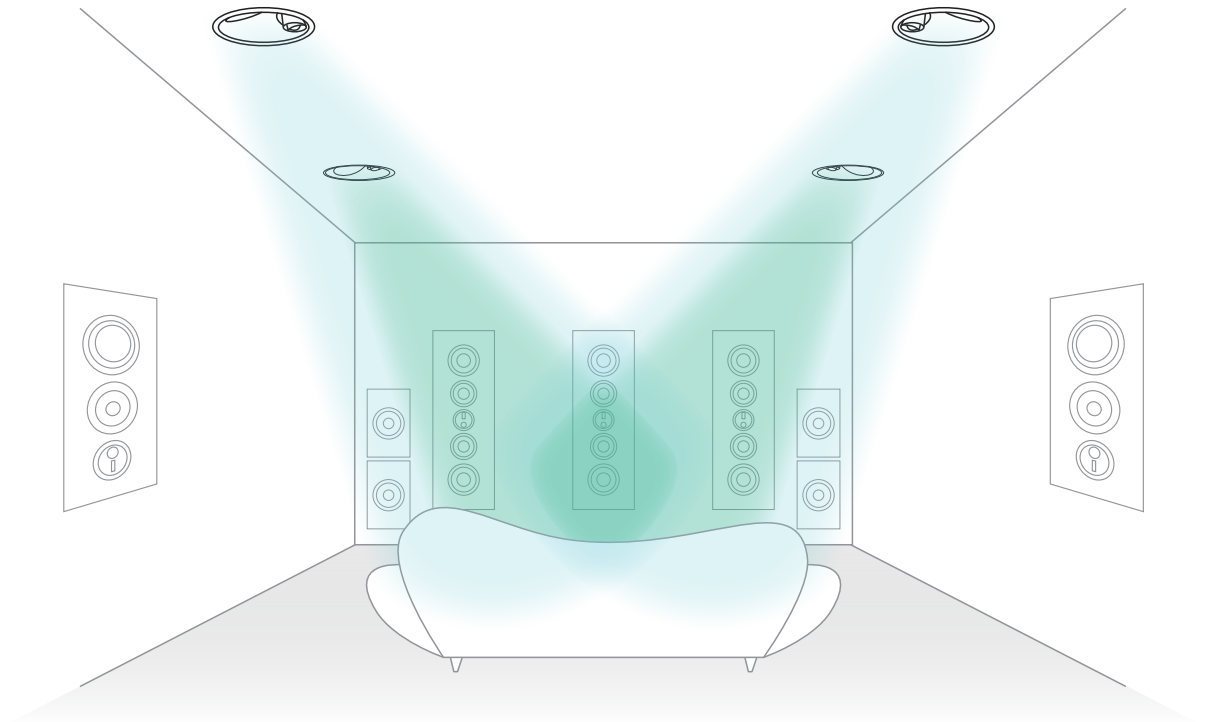

In-ceiling Surround Sound

One reason some people can be reluctant to embrace 5.1 channel home theatre is the quantity of loudspeakers that will consume floor or wall space in what may be an already crowded living space.

The PHANTOM M-80 A in-ceiling loudspeaker however, with its high performance, full bandwidth capabilities, can solve both problems at a stroke while covering Left, Centre, Right and Surround channel roles – mounted in the ceiling. Wall or floor space is not occupied because all loudspeakers can be in-ceiling mounted, and cable runs can be contained within the ceiling void rather than being draped across the floor or chased into walls.

In addition to its high performance, the PHANTOM M-80 A is able to cover all the home theatre channel roles thanks to the directional radiation that arises from its angled driver architecture. This means that by rotating the M-80 A's in their mounting apertures, their acoustic radiation can be directed as required towards the listening area and will create the sense that the sound is coming from the tv, and not from the ceiling.

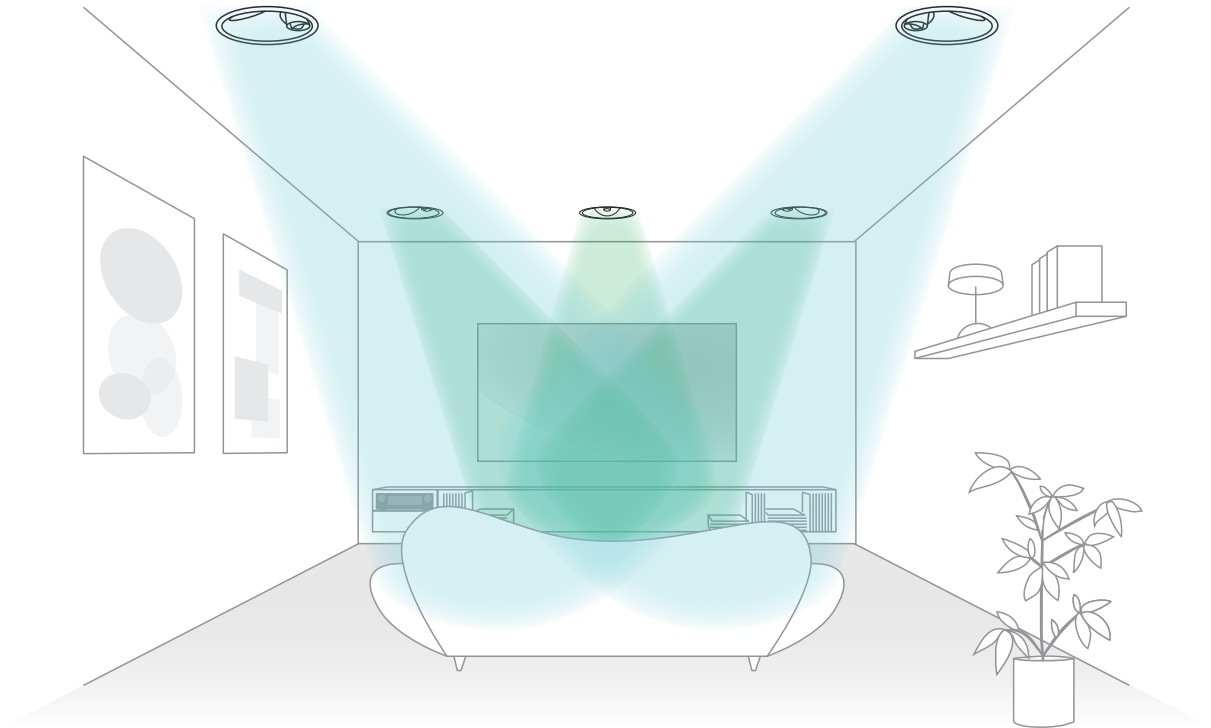

In-ceiling Stereo

A typical high-performance stereo system requires floor or wall mounted loudspeakers. Some people prefer not to have traditional speakers taking up floor or shelf space in the living room. The PHANTOM M-80 A can provide an exceptional alternative option to a pair of traditional box-speakers. A pair of M-80 A loudspeakers placed in the ceiling, where the floor-standing loudspeakers would otherwise be located, can be rotated in their mounting apertures so that their radiation is directed towards the listening position.

The result is very high-performance reproduction with an expansive, height-enhanced stereo image that brings an extra element of involvement and engagement to listeners thanks to the concealed nature of in-ceiling loudspeaker installation.

The combination of the M-80 A's high-end electro-acoustics with its angled driver architecture effectively re-writes the rules of conventional stereo in the home.

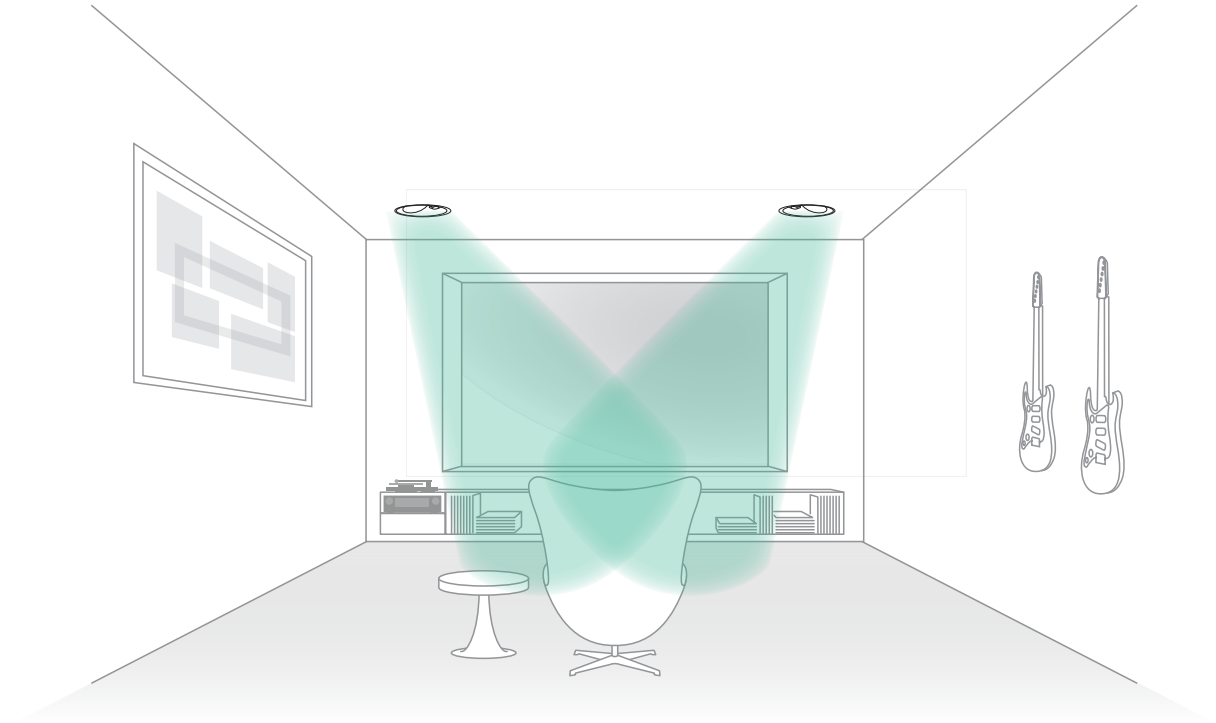

Sounds From Room Boundaries

Conventional in-ceiling loudspeakers, typically have an acoustic radiation characteristic that is predominantly vertically downward, which makes mounting near walls or corners less than ideal.

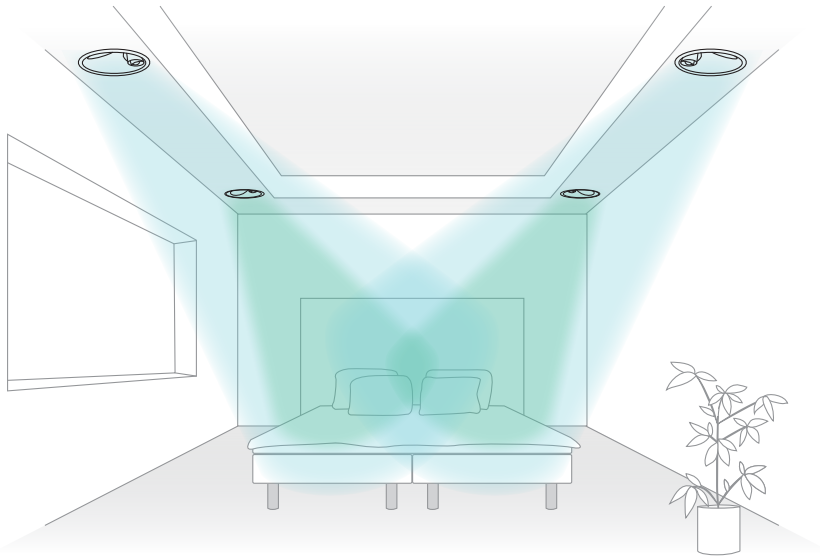

Example 1: Bedroom with speakers located near the walls.

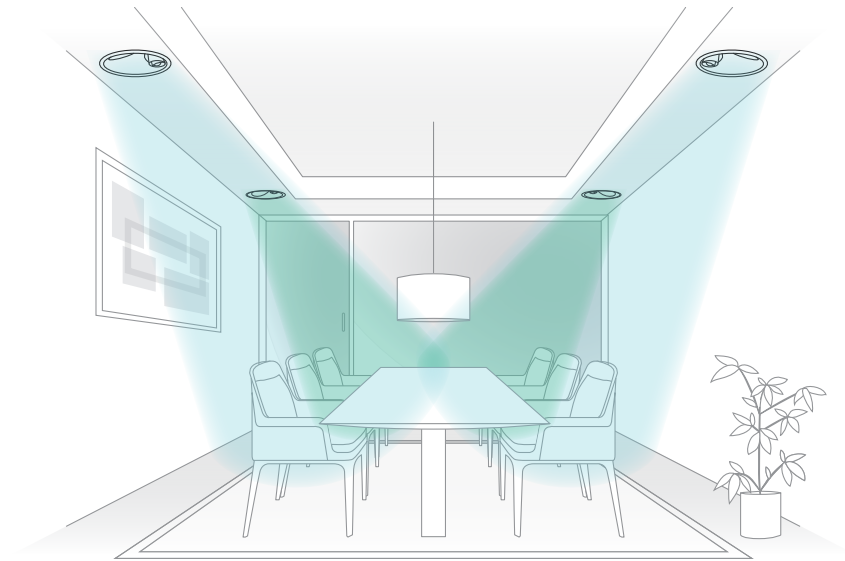

Example 2: Dining Room with speakers located near the walls.

The PHANTOM M-80 A however can handle corner or near wall locations because of its angled driver architecture. In combination with rotation in the Compass mounting aperture, ensures that less acoustic energy is directed towards nearby boundaries and ensures optimum dispersion for the specific audio installation to maximise sound quality at the listening position. The M-80 A makes it possible for a wider range of installation options than are often feasible with conventional in-ceiling loudspeakers.

This makes the M-80 A a fantastic performer, in nearly any situation or use case.

Pivoting tweeter housing

The tweeter housing allows for manual pivoting. Adjust the tweeter angle so that it points towards the main listening position / listening area.

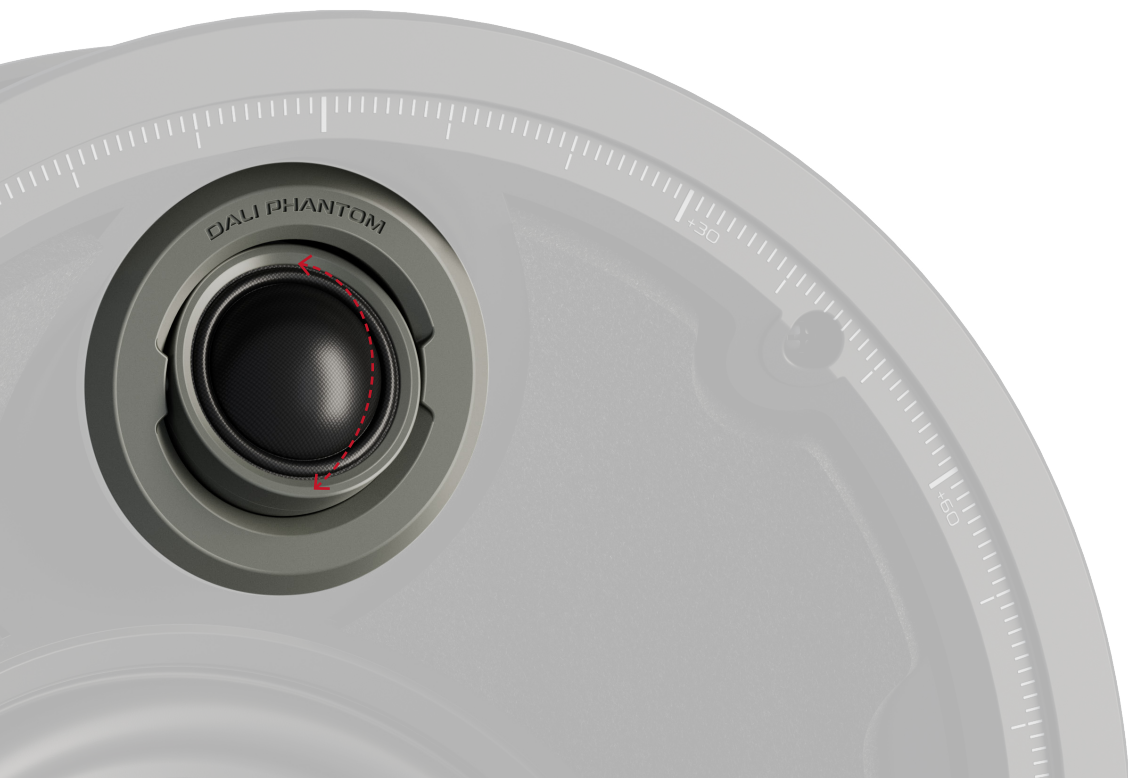

Switch adjustable tone controls

The front bezel of the M-80 A incorporates two slide switches: Normal/High+ and Normal/Mid+.

The Normal/High+ switch offers 0dB or +3dB tweeter level options, while the Normal/Mid+ adjusts the midrange frequencies from 0dB to +3dB.

The High+ function can be used either for compensation of subjectively suppressed high frequencies when listening at a distance or off-axis, or simply if personal listener preference is for a brighter high frequency balance.

The Mid+ switch gives the user a quick and easy choice between a slightly recessed midrange for a warm and full sound or a more linear midrange response for at more precise and neutral representation.

- ! When listening relatively close to the center axis of the loudspeaker (closer than 25 degrees off-axis) we recommend setting the switches to the “Normal” setting. When listening far away from the center axis of the loudspeaker (more than 25 degrees off-axis) or if the speaker is used to fill a large area with sound, we recommend setting the switches to “Mid+ and High+”.

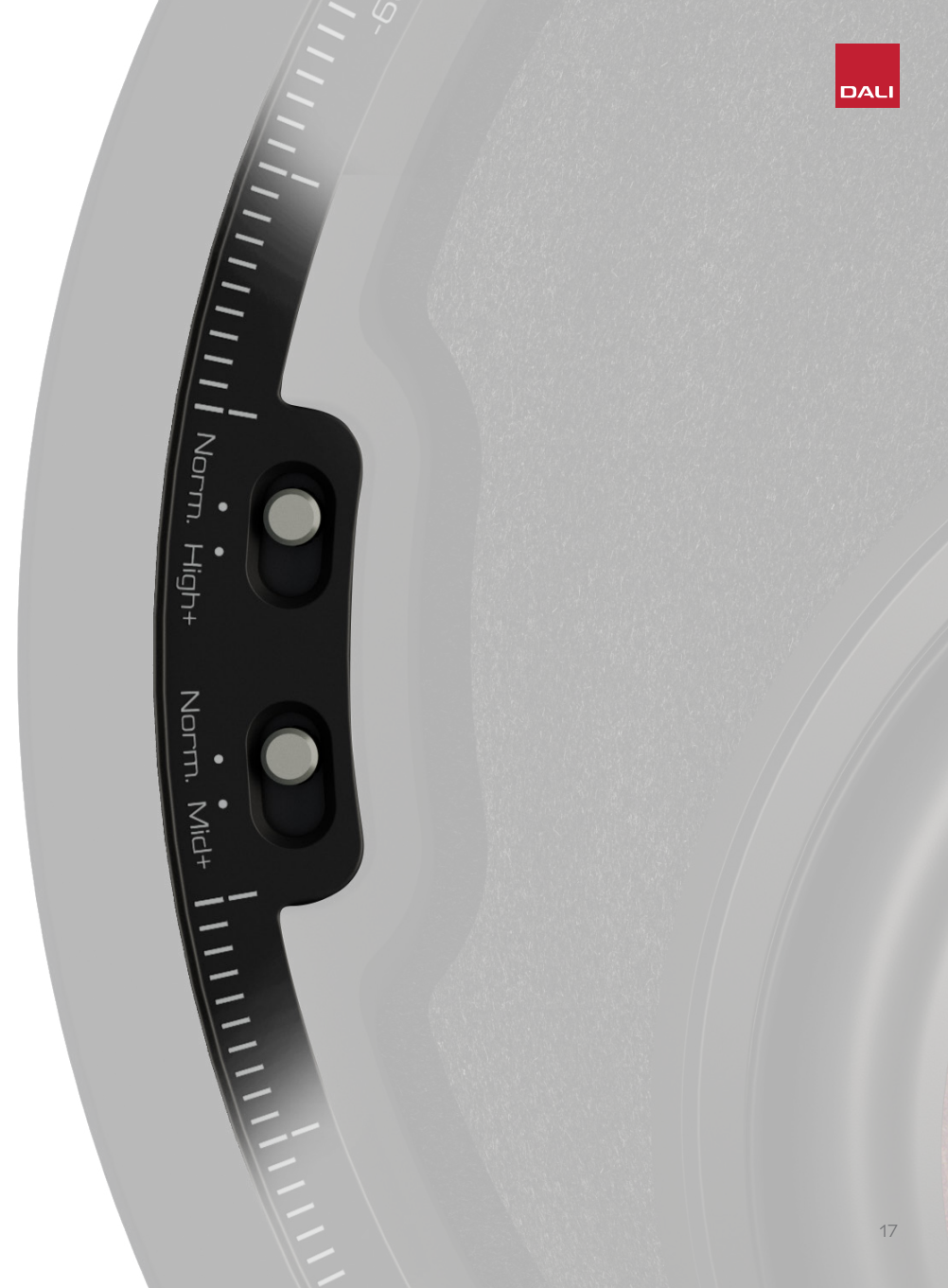



DALI PHANTOM
M-80 A

Norm. High+

Norm. Mid+