



DALI EPIKORE 11

MANUAL
EN



Contents

1. Introduction	2
2. EPIKORE 11 Accessory Kit	3
3. Unpacking your loudspeakers	4
4. Positioning your loudspeakers	9
5. Connecting your loudspeakers	10
6. Using your loudspeakers	12
7. Cleaning and maintenance	13
8. Disposal	13
9. Specifications	14

1. Introduction

Thank you for choosing the DALI EPIKORE 11.

DALI is renowned throughout the world for continually striving to enhance the experience of music in the home, and the DALI EPIKORE 11 is an extraordinary expression of that endeavour.

The DALI EPIKORE 11 is a high performance loudspeaker that performs best when installed correctly. We therefore recommend that you explore this manual thoroughly before unpacking, installing or using your loudspeakers.

The DALI EPIKORE 11 is extremely heavy, so to minimise the risk of damage or personal injury, please carefully follow the unpacking instructions.

We hope you enjoy your DALI EPIKORE 11 loudspeakers for many years to come.

2. EPIKORE 11 Accessory Kit

The DALI EPIKORE 11 Accessory Kit contains the tools and accessories needed to install and optimise the performance of your loudspeakers. The contents of the Accessory Kit are shown below.

! If you plan to relocate your DALI EPIKORE loudspeakers in the future, we recommend that you store the packaging materials.

Document Pack:

- 1 × Manual
- 1 × Inlay Card
- 1 × Cleaning cloth

Accessory Box:

- 4 × Spike outriggers (two pairs) **A**
- 4 × Lock nut thumbscrews **B**
- 4 × Magnetic spike feet **C**
- 8 × M8 x 20 mm screws **D**
- 8 × M8 washers **E**
- 2 × Terminal jumpers **F**
- 2 × Floor protection pads **G**
- 1 × 5 mm Allen key **H**
- 1 × Magnetic front grille (located in the shipping crate) **I**

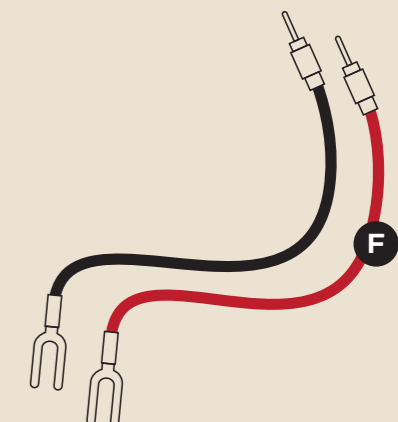
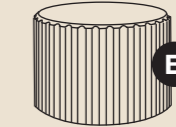
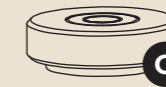
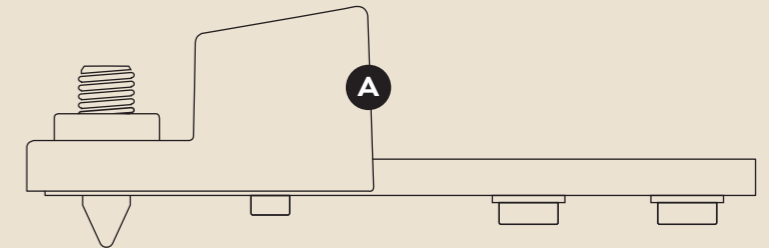
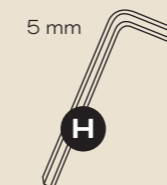

3. Unpacking your loudspeakers

We recommend unpacking DALI EPIKORE 11 loudspeakers close to their intended final position. DALI EPIKORE 11 loudspeakers are delivered in pairs standing upright on one Euro pallet.

EPIKORE 11 loudspeakers are heavy so unpacking should be undertaken by two people working together.

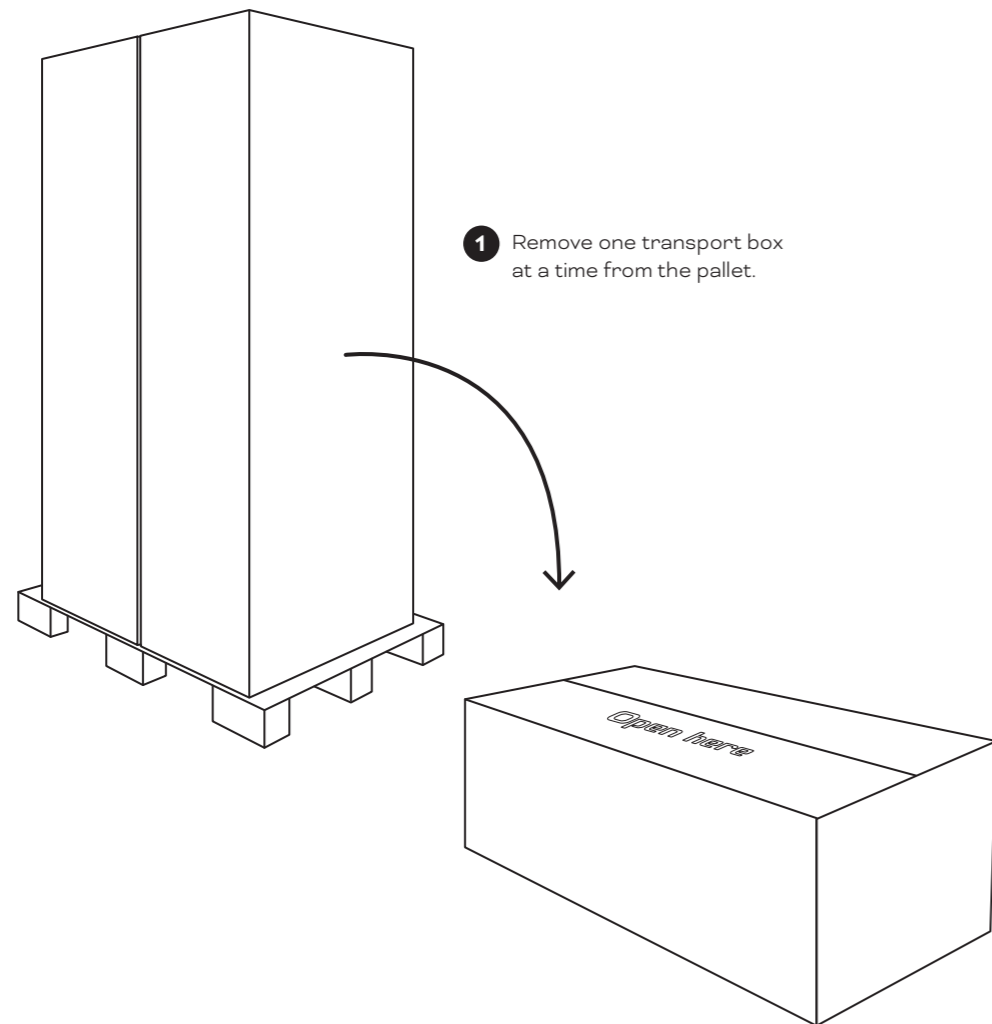

! If you need assistance with the installation, please contact your local DALI dealer.

2 Place an EPIKORE 11 shipping crate on its back and carefully open the carton. Bend the cardboard flaps down and ensure the carton is fully open. **A**

Lift the EPIKORE 11 grille out of the carton and place it out of the way. **B**

Slowly flip the carton 180° ensuring that the cardboard flaps remain open. **C**

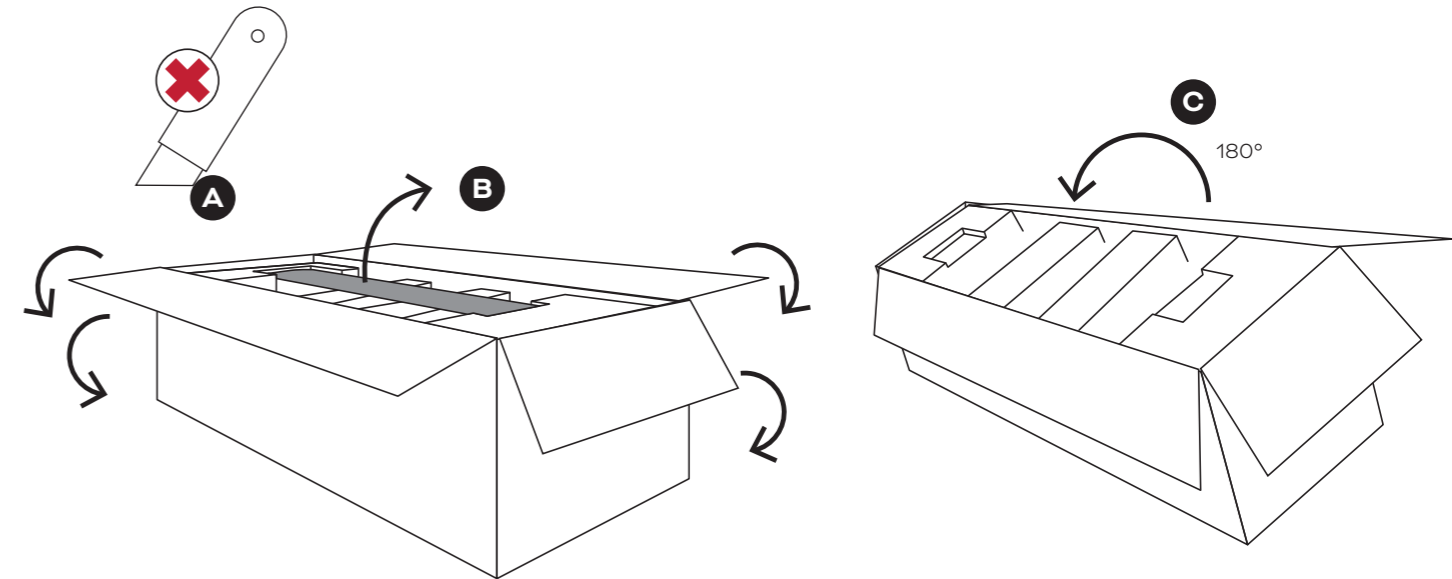

3 With the carton now lying on its front it can be lifted away, leaving the EPIKORE 11 held in its inner packaging.

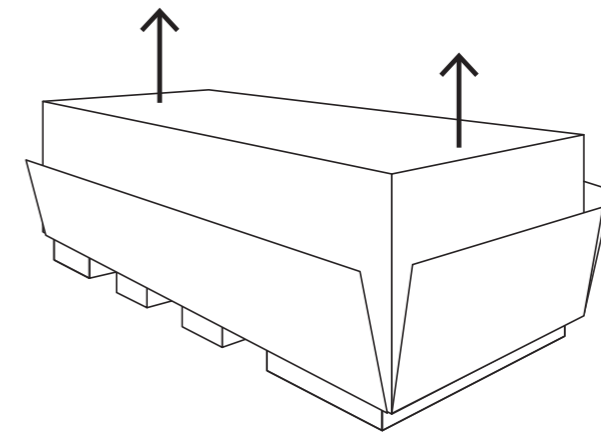

4 Remove the accessory box. **A**

Remove the top halves of the centre packing blocks **B**, and the two packing end caps **C** to leave the EPIKORE 11 supported by the remaining centre packing blocks. Open the cabinet protection cloth in the bottom of the loudspeaker **D**.

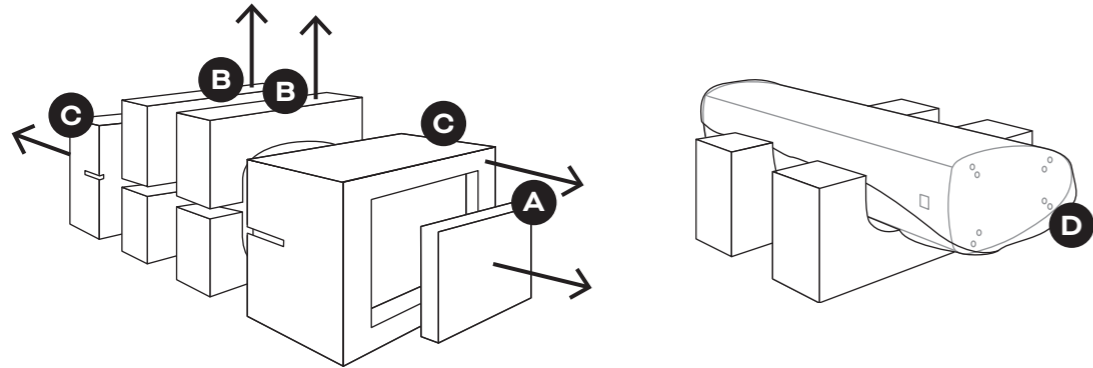

5 Place a spike outrigger **A** in position on the bottom panel of the EPIKORE 11 and use its attachment screws **B** and the 5 mm Allen key **C** to secure it in position. Tighten the screws fully.

Repeat for all four spike outriggers.

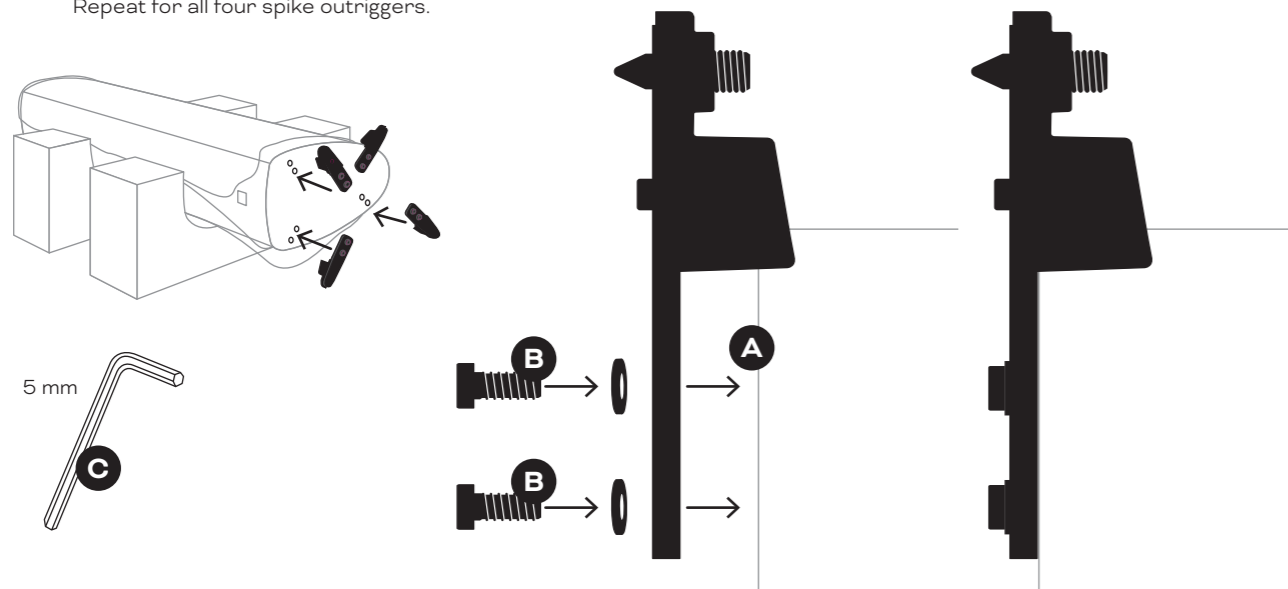

6 Apply the two magnetic spike feet **A** to the spike outriggers **B** positioned at the top-facing side of the loudspeaker.

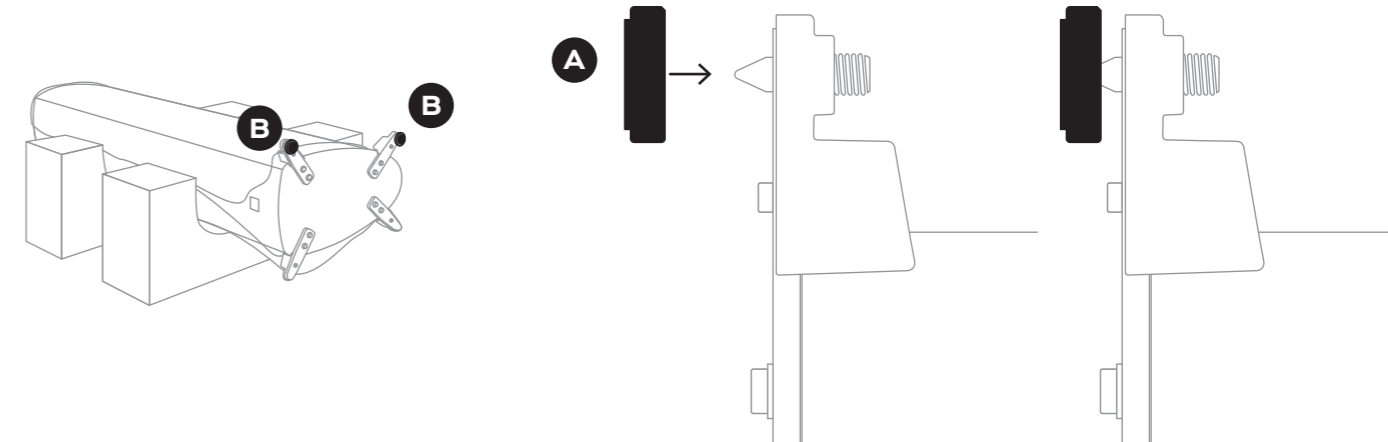

7 Apply two floor protection pads to the spike feet closest to the floor **C**.

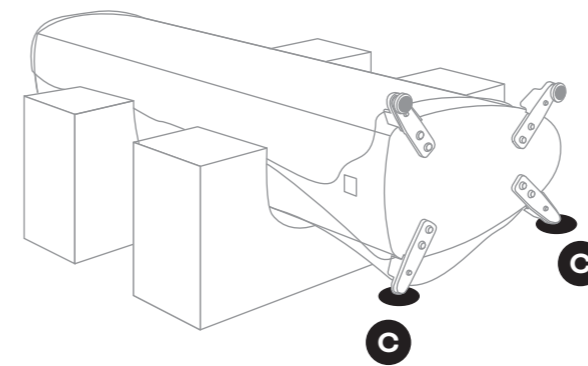

8 Remove the EPIKORE 11 cabinet protection cloth and carefully raise the loudspeaker to its upright position at its operational position.

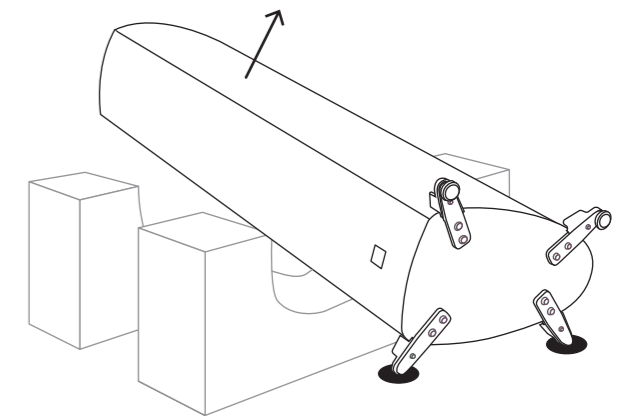

- 9** Carefully tilt the EPIKORE 11 to the side with the magnetic spike protectors attached, so that the floor protection pads can be removed.

If the magnetic spike protectors are to be used, apply the two remaining spike protectors under the spikes on one side while the loudspeaker is tilted. If the spike protectors are not to be used, remove the previously applied spike protectors by tilting the speaker to the other side.

Adjust the spikes **A** so that the loudspeaker is stable using the 5 mm Allen key. **B**

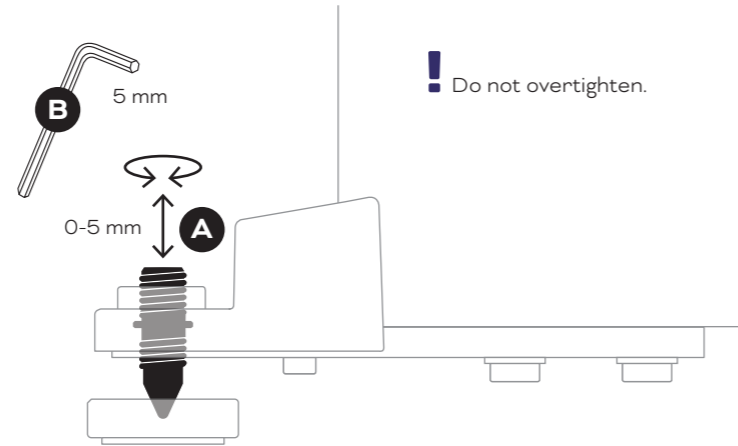

- 10** Screw a lock nut thumbscrew **A** by hand to the top of each Spike.

Remove the EPIKORE 11 tweeter dome protector **B**.

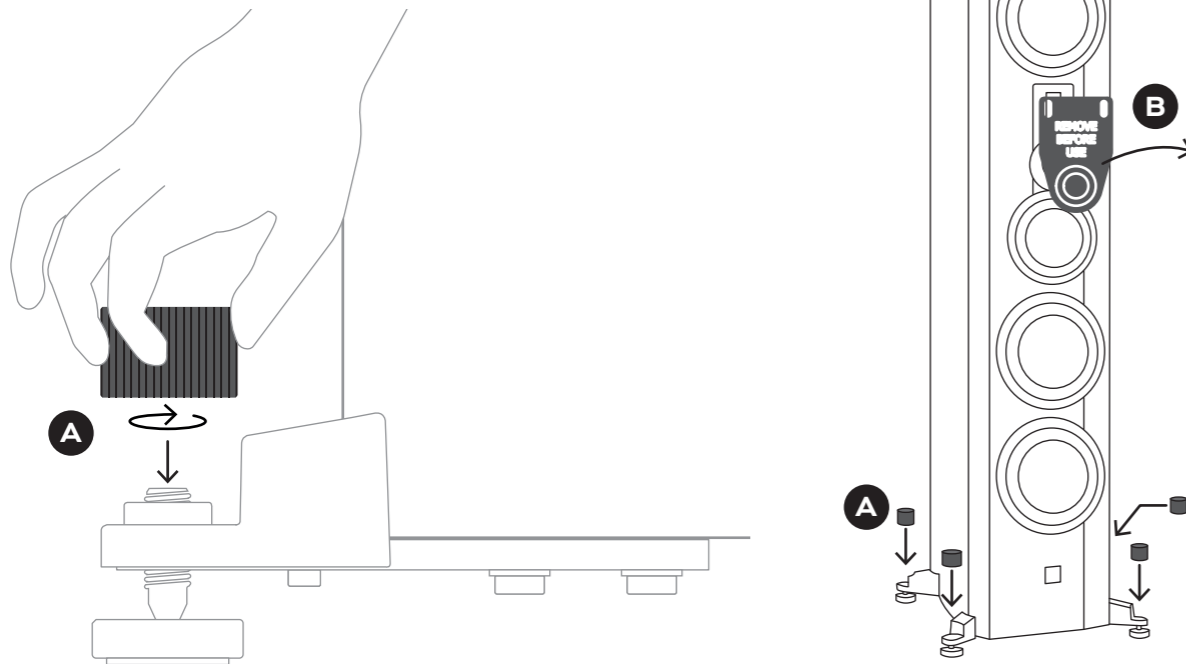

4. Positioning your loudspeakers

In this section, we guide you through placing your DALI EPIKORE 11 loudspeakers in your listening room. You'll likely need to make position adjustments as you become familiar with the performance of the speakers, so you may need to revisit the spike feet adjustment steps described in the previous paragraph.

The sound of any loudspeaker is influenced by the space and position in which it's located. Even small changes in position can significantly influence the sound. Changes to a room, such as laying a rug or closing a pair of heavy curtains, can also have an effect.

Position your EPIKORE 11 loudspeakers 3 to 5 metres apart, well away from corners in the room and 1 to 2 metres from the rear wall. The distance between the loudspeakers and the rear wall is where you're likely to make adjustments as you become more familiar with their performance in your room.

The primary listening position should be located centrally between the loudspeakers, at approximately the same distance as that between the loudspeakers (Diagram 1).

As DALI loudspeakers are designed to offer wide acoustic dispersion, we recommend that you avoid

angling (or toeing-in) your DALI EPIKORE 11 loudspeakers towards the listening position.

Try to position each DALI EPIKORE 11 loudspeaker in an acoustically similar environment. Curtains, windows, bookcases and other nearby objects can all affect a loudspeaker's acoustic performance.

If you move your DALI EPIKORE 11 loudspeakers closer to a wall boundary, the low frequency elements of your music are likely to become more prominent. Although this might initially appear to improve the sound, it can be at the expense of musical clarity and accuracy.

Diagram 1: Positioning guidelines

Positioning your loudspeakers

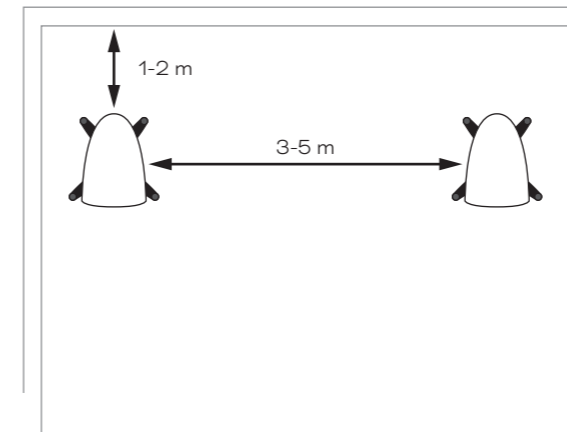

Finding the optimal listening position

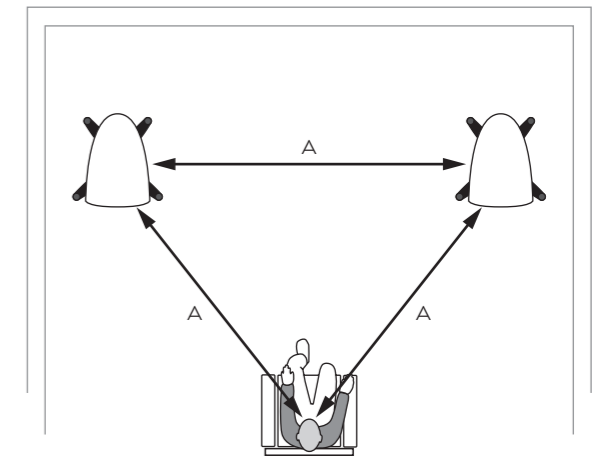

5. Connecting your loudspeakers

Each DALI EPIKORE 11 loudspeaker is fitted with two pairs of binding post terminals on its rear connection panel. The upper pair of terminals is connected to the midrange and Hybrid Tweeter module, while the lower terminal pair is connected to the bass drivers.

Included in the Accessory Kit are two Terminal Jumpers per speaker, which can be used to connect the pairs of positive and negative binding posts so that only a single twin-core speaker cable is required to connect each speaker to a single power amplifier. If the terminal jumpers are removed, two twin-core speaker cables will be needed, sharing the output from a single power amplifier in a “bi-wire” format.

Diagram 2 shows single-wire, bi-wire and bi-amp connection formats.

The specification and type of loudspeaker cables you use to connect your DALI EPIKORE 11 loudspeakers can influence their audio performance. For best results, use high quality cable with a minimum conductor cross-sectional area of 2.0 mm². Each speaker cable should be of similar length and less than 20 metres long. Your DALI EPIKORE 11 retailer will be happy

to offer advice on the best speaker cable for your setup.

When connecting your DALI EPIKORE 11 loudspeakers to an amplifier, begin by connecting the speaker cables to the loudspeaker terminals. Ensure that the cable wires marked “positive” or coloured red are connected to the positive (red) loudspeaker terminals, and “negative” or black cable wires are connected to the negative (black) loudspeaker terminals.

The DALI EPIKORE 11 connection terminals can accommodate stripped cables, 4 mm plugs or cable spades.

Here’s how to connect each type:

- **Stripped cables:** Unscrew the loudspeaker terminals fully. Twist the stripped cable strands together, ensuring there are no stray strands, and insert the cable into the holes through the terminal posts. Finally, tighten the terminals down onto the stripped cable securely. We recommend checking the terminals for tightness soon after you first tighten them and periodically thereafter.

- **4 mm plugs:** Insert the plugs directly into the end of the loudspeaker terminals.
- **Cable spades:** Fully unscrew the loudspeaker terminals and position each cable spade arm either side of a terminal post. Secure the cable spades by tightening the terminals. We recommend checking the terminals for tightness soon after you first tighten them and periodically thereafter.

With cables connected to your DALI EPIKORE 11 loudspeakers, they can now be connected to the amplifier’s output terminals. Ensure the amplifier is switched OFF before you make any connections.

Connect the cables from the left loudspeaker to the amplifier’s left channel output terminals, and the cables from the right loudspeaker to the amplifier’s right channel output terminals. Ensure that the cable wires marked “positive” or coloured red are connected to the positive amplifier output terminals, and wires marked “negative” or coloured black are connected to the negative amplifier output terminals.

! When bi-wiring or bi-amping, ALWAYS remove the terminal jumpers between the terminals before connecting the speaker cables.

Diagram 2: Connecting your loudspeakers

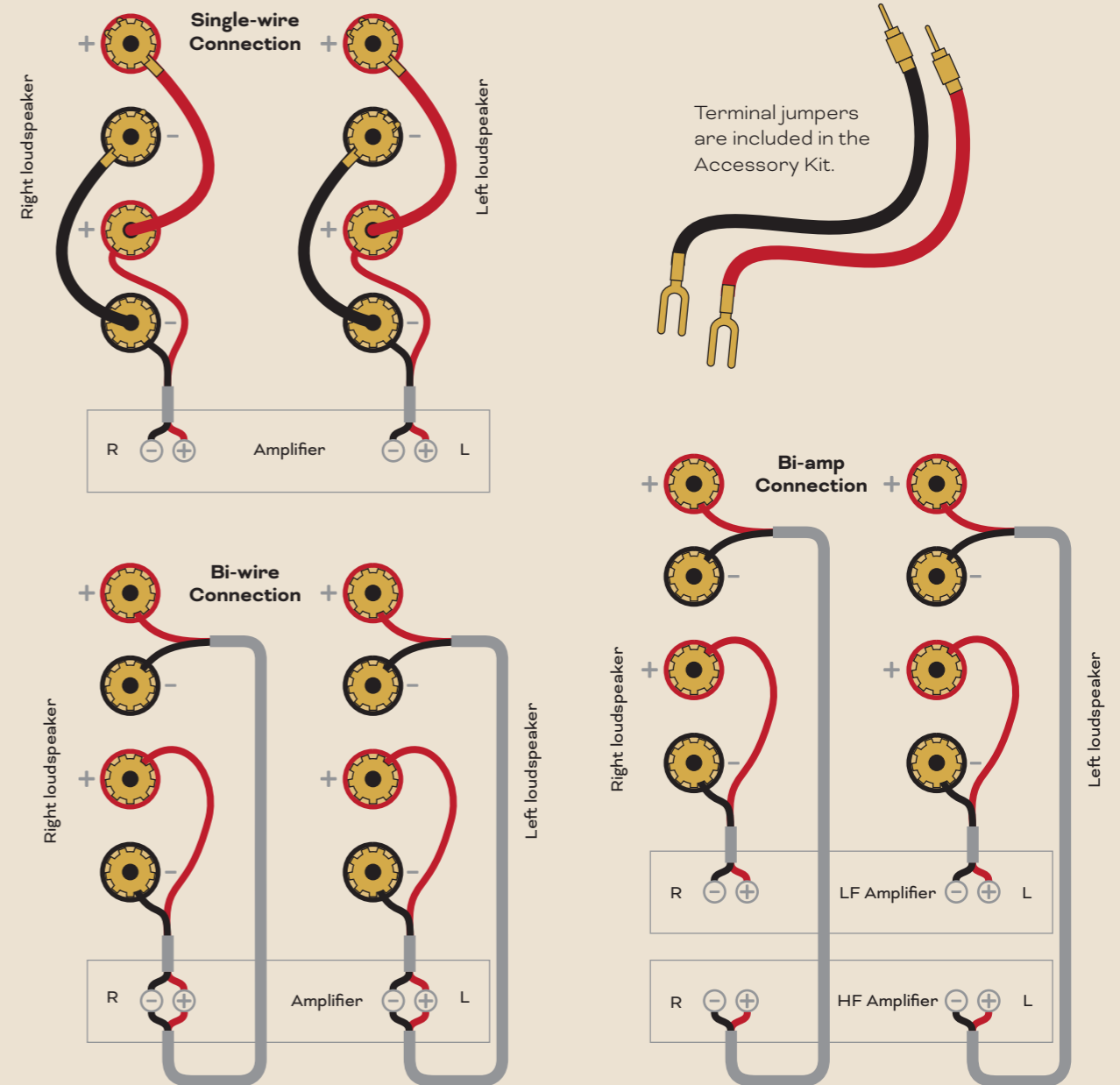

6. Using your loudspeakers

Now that your DALI EPIKORE 11 loudspeakers are installed in your listening space and connected to one or more amplifiers, the next step is to start enjoying them. So, find your favourite music, take a seat and get ready to rediscover your music collection.

The front grille

Use of the front grille is optional. To attach the grille, carefully move it close to the front baffle until the magnets pull it into position. To remove the grille, carefully pull its top to loosen it and then take it off.

Running in

Your DALI EPIKORE 11 loudspeakers will experience a “running-in” period before they perform optimally, especially if they have been exposed to prolonged low temperatures during shipping or storage. Although the running-in period will vary depending on the intensity of use and playback volume, you should expect your DALI EPIKORE 11 loudspeakers to perform at their best after up to 100 hours of use. Unlike many other mechanical devices, the lifespan of a loudspeaker will increase with regular use.

Precautions

If your amplifier is able to deliver enough power, your DALI EPIKORE 11 loudspeakers are capable of extremely high volume levels. Please remember that listening to music for extended periods at high volume can damage your hearing. Also, be considerate of those you live with and others nearby. If the sound from your DALI EPIKORE 11 loudspeakers becomes distorted, this is a sure sign that your amplifier is running out of power. To avoid damaging your loudspeakers or amplifier, reduce the volume until the music no longer distorts.



7. Cleaning and maintenance

Your DALI EPIKORE 11 loudspeakers need no special maintenance or care and should be treated as any other valuable item of furniture in your home. Remove dust from the cabinets with a soft dry cloth, and clean them using a soft damp cloth with a mild all-purpose, non-abrasive household cleaning agent. Use caution when dusting the bass or midrange driver cones as they are extremely fragile. We also recommend that you avoid touching the tweeter dome and ribbon tweeter altogether.

8. Disposal

If you want to dispose of your DALI EPIKORE 11 loudspeakers, don't mix them with your general household waste. In accordance with EU legislation, a separate collection system for used electronic products enables private households in EU member states, Switzerland, Liechtenstein and Norway to return used electronic products free of charge to designated collection facilities or to a retailer (if you purchase a similar replacement product). If you reside in a country not mentioned above, please contact your local authorities to determine the correct method of disposal and prevent any potential negative effects on the environment and human health.



9. DALI EPIKORE 11 Specifications

Frequency range	29 - 34.000 Hz ±3 dB	
Sensitivity	89 dB @ 1 m for 2.83 V	
Nominal impedance	4 ohm	
Maximum SPL	116 dB	
Crossover frequency	170 / 370 / 3,100 / 12,500 Hz	
Crossover principle	4½-way	
Recommended amplifier power	40 - 1000 Watt	
High frequency driver(s)	10 × 55 mm ribbon 1 x 35 mm soft dome	
High frequency diaphragm	Planar electrostatic ribbon Soft woven fabric	
Low/Mid frequency driver(s)	4 x 8 inch 1 x 6½ inch	
Low/Mid frequency diaphragm	Wood fibre cone	
Connection input(s)	Bi-wire	
Enclosure type	Bass reflex	
Bass reflex tuning frequency	24 Hz	
Recommended placement	Floor	
Recommended distance from rear wall	35 - 120 cm	
Dimensions (H x W x D)	1602 x 422 x 554 mm 63 x 16.6 x 21.8 inches	
Weight incl. grille	75.6 kg 166.6 lb	
Shipping weight	176 kg (pair) 388 lb (pair)	
Finishes	High Gloss Black High Gloss Walnut High Gloss Maroon	
Accessories	Manual Inlay card Cleaning cloth Spike outriggers (two pairs) Magnetic spike feet	Terminal jumpers Floor protection pads 5 mm Allen key Magnetic front grille
Spike thread size	M12-1	

The information provided in this manual is subject to change without notice.